

# Application and potential of guided wave rail inspection

J L Rose, M J Avioli and W-J Song

*Three applications of guided waves for rail inspection in the railroad industry are considered: fixed sensors on rail; a guided wave rail inspection car; and a sensor-on-train system. Basic elements of guided wave analysis, reflection and transmission principles, penetration power, modes of energy induction and reception, sample experiments on air transducers, cut rail, successes to date and future directions are discussed.*

*Dr Joseph L Rose is the Paul Morrow Professor of Engineering at Penn State University.*

*Dr Rose received his PhD from Drexel University in 1969. He received a variety of awards and was a finalist in the 1995 Discover Awards for technological innovation in Aviation and Aerospace for the development of a hand-held probe for ageing aircraft inspection. He was also the recipient of a University Faculty Scholar Medal for achievement in Engineering in 1996, an outstanding research award in 1997, and a premier research award in 2002. He was also the ASNT Mehl Honour Lecture recipient in 2001.*

*Dr Rose is author of over ten patents, four text books, and over 400 articles on ultrasonic NDE, wave mechanics, medical ultrasound, adhesive bonding, concrete inspection, pipe and tubing inspection, and composite material inspection. Textbooks include Basic Physics in Diagnostic Ultrasound, John Wiley & Sons Inc, New York, 1979, and Ultrasonic Waves in Solid Media, Cambridge University Press, 1999. He has served as principal advisor to over 40 PhD students.*

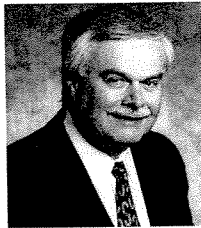

*Dr Michael J Avioli, a research associate of FBS, Inc in State College, Pennsylvania, USA, has over twenty-five years of ultrasonic NDE experience. He has participated in over 40 projects involving applications of signal processing and pattern recognition technology in ultrasonic NDE. Many of these projects were managed by him during his 8½ years as a project manager with the Electric Power Research Institute (EPRI) and many recently with FBS, Inc.*

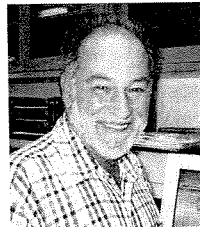

*Prior to joining EPRI, he was director of research for Ultrasonic International, Inc. In that position he was responsible for innovative software packages that enabled users to perform pattern recognition oriented post-processing of ultrasonic NDE data.*

*Dr Won-Joon Song is working as a Post-doctoral research associate in the Penn State Ultrasonic Lab. He received a PhD degree from the Department of Mechanical Engineering at Northwestern University in December, 2000 and BS degree from the Department of Mechanical Engineering at Pusan National University, Korea in February, 1996.*



*He is interested in conducting research, both experiments and analytical computations, on non-destructive evaluation and testing with ultrasonics. Currently he is involved in researches on damage detection in a ship hull, pipes, rail, and multi-layer structures using ultrasonic guided waves.*

*Address for correspondence: 411 E Earth & Engineering Sciences Building, Dept of Engineering Sciences and Mechanics, Penn State University, University Park, PA 16802, USA. Tel: +1 (814) 863-8026; Fax: +1 (814) 863-8164; E-mail: jlresm@enr.psu.edu*

## Introduction

The widespread applications of guided wave inspection technology are outlined in the literature<sup>[1]</sup>. Basic physics and mechanics of guided wave propagation can be found in further studies<sup>[2]</sup> and recent work on guided wave inspection of rail is reported elsewhere<sup>[3,4]</sup>.

A rail is a natural wave-guide. Energy is trapped in the rail as it propagates. Wave interference occurs as the wave modes convert and bounce back and forth until various wave packets of energy are formed. Basic principles of dispersion curve and wave structure analysis typical of those discussed in the literature<sup>[2]</sup> are applicable, but effects now become three-dimensional. Wave propagation is more complex. Certain modes and frequencies may not be able to inspect a rail in all locations, head, web, base for example. One possible wave structure from hundreds of possibilities is illustrated in Figure 1 for displacements  $u$ ,  $v$ , and  $w$ , in the  $x$ ,  $y$ , and  $z$  directions respectively. For the sample result shown, defects in the head or base could be detected reasonably well, but with almost no detection possibility in the web. However, for another mode and frequency, some sensitivity in different areas would be obtained. A combination of theoretical and experimental analysis will be necessary to carry forward development of a complete rail inspection protocol.

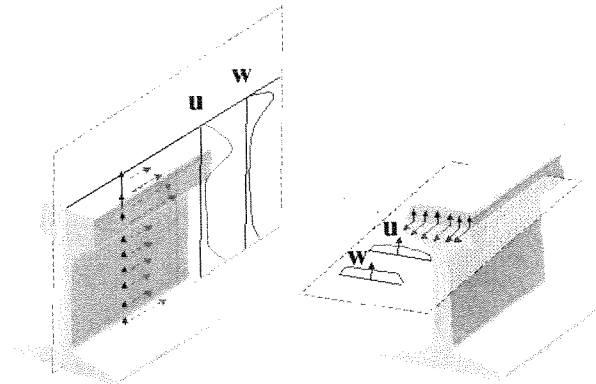

**Figure 1. Three-dimensional wave structure distribution possibility along slices of rail for a particular mode  $R_i$  and frequency  $F_i$ .**

Three possibilities exist for guided wave rail inspection. They are considered in this paper, each of which are briefly discussed below.

### □ Fixed sensors on rail

If it were possible to place sensors permanently on a rail, located for example every two or three miles, it would be possible to implement an inspection for broken rail in a very straight-forward fashion. An activator could be used, possibly consisting of an impact device or a 20, 40 or even 60 kHz excitation source, whereby the simple techniques of pulse echo and through-transmission could be used to isolate broken rail situations. The train itself could be used as a source, since ultrasonic energy is induced into the rail from the moving train.

□ *Guided wave rail inspection car*

It is possible to develop a guided wave rail inspection car that could travel up to say 30 miles per hour along a rail with ultrasonic transducers mounted say 30, 40, or 80 feet apart, whereby energy can be induced into the rail at one end and received at the other end. A variety of different transducer arrangements could be considered, included laser vibrometry, EMAT technology, or air transducers. Some sample results are presented in this work that illustrate how these techniques are being developed. Some signal processing is required to separate the train motion noise from the actual induced and received ultrasonic signals travelling in the rail. The natural wave filtering characteristics of the rail and specific induced kinds of energy would make this possible.

□ *Sensors on a train*

An interesting idea would be to include sensors on a train. One example would be to use laser vibrometry or air probes that could actually see defects far ahead of the train as it moves down the track at some distance, say two, three, or four miles away. Ultrasonic energy and vibrational patterns would propagate forward from the moving train and reflected signals would modify the patterns recorded by the transducer if defects were encountered. Using basic physics and mechanics, some signal processing and pattern recognition, it would be possible to identify broken rail and critical situations lying ahead of the train's locomotive. A feasibility study is reported in one paper<sup>[31]</sup>. Harmonic wave induction into the rail is possible via Hertzian contact loading between the wheel and the rail, which serves as a moving line source. This coupled with the comb-like sleeper spacing, wheel spacing, rail lengths, etc. imparts a large range of harmonic motions into the rail. There are obviously many limitations to the method that would have to be overcome, for example rail turn-outs, switches, road crossings, thermite welds in a structure and so on. An examination of various wave propagation and vibration patterns indicates that these limitations could possibly be overcome.

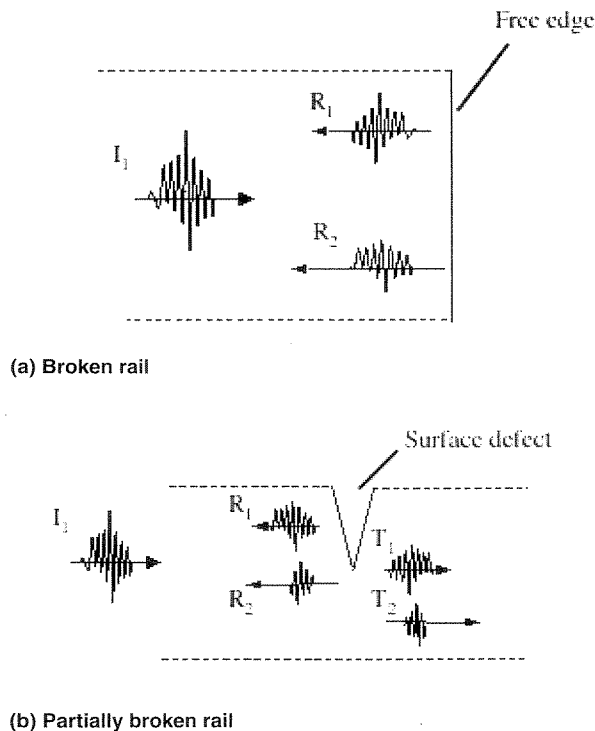
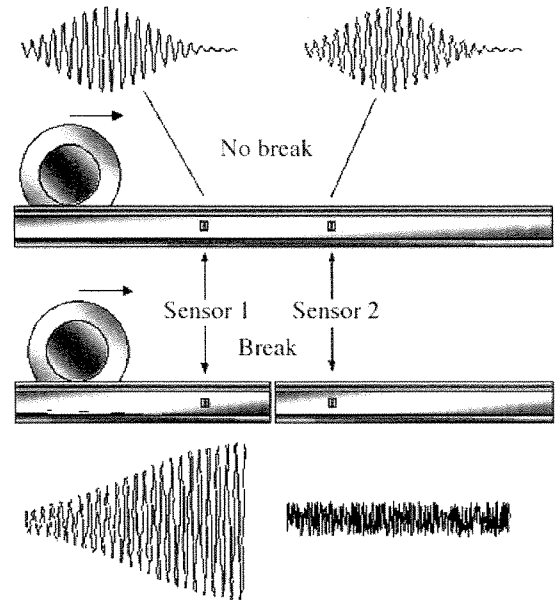

Figure 2. Guided wave reflection principle concept: illustration of mode conversion in the neighbourhood of broken rail

Some basic aspects of wave propagation in a rail that would produce certain reception patterns are illustrated briefly in Figures 2, 3, and 4. As an ultrasonic wave impinges on a defect or an interface between two materials, there is wave reflection and transmission that occurs at that anomaly because of guided wave properties and boundary conditions at the anomaly. Many modes can be reflected and many transmitted. Constant frequency (vertical line) analysis on a dispersion curve identifies the modes that could contribute transmitted or reflected energy. Each mode travels with its own group velocity and amplitude depending on the defects that are encountered. Natural solutions of the boundary conditions associated with the wave propagation problem show this. Both finite element and boundary element techniques are being used to study this reflection and transmission problem in a variety of different structures and for a variety of different defect shapes and sizes (see Figure 5, for example). Figure 2 shows a schematic of this wave reflection and transmission possibility.

If we go further and look at Figure 3 as an example, imagine a train coming down the track and imparting energy into the rail. If there were no break in the rail, the energy received by the sensor fixed on the train would remain roughly the same with respect to the random variations occurring as the train travels down the



i) Pulse echo response      ii) Through-transmission response

Figure 3. Projected sensor time history of elastic wave energy as train approaches sections of instrumented rail with no break and also instrumented rail with a break

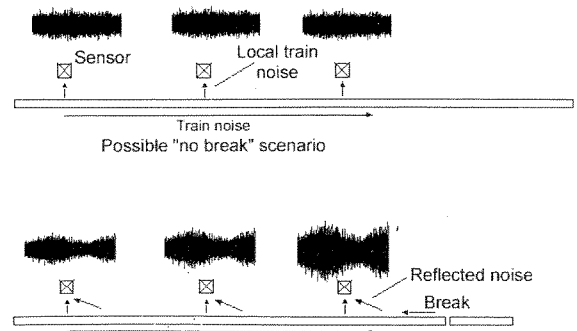

Figure 4. Possible wave modulation in waveform from a 'break' versus 'no break'

rail. On the other hand, if a reflection occurs, it superimposes on to the sending energy, causing all sorts of variations manifesting themselves as modulations of the waveform being examined (for example, time-varying amplitude, etc.) This scenario is illustrated in Figures 3 and 4.

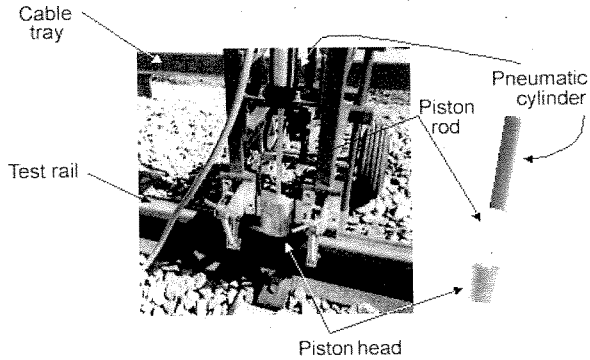

Figure 5. Rail impactor device

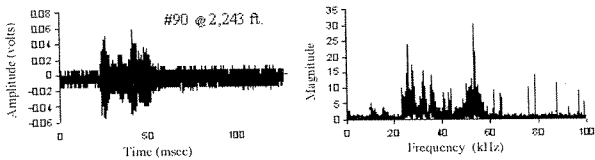

Figure 6. Sample received RF waveform and frequency spectra from a source 2243 ft away

### Penetration power studies

A number of different techniques were used to induce ultrasonic energy into a rail. One interesting technique is illustrated in Figure 5, where a rail impactor device was used to examine the natural filtering effect of the rail on waves travelling in it. A sample result acquired approximately 2000 ft away from an impactor source is illustrated in Figure 6. An accelerometer was used to acquire the data. The group velocity in the rail was approximately 3 mm/ $\mu$ s. Notice the frequency content. Significant content exists between 25 kHz up to 58 kHz, showing the ultrasonic ranges of wave propagation that might be considered in the structure.

Some interesting conclusions could be drawn from this work which was performed at the Bay Area Rapid Transit system test track in Hayward, California. The attenuation of guided wave ultrasonic energy in rail is frequency-dependent and higher frequency waves in this case actually travelled further and faster than the lower frequency ones. Three ranges of frequency can be defined: an audio, mid-range, and so-called ultrasonic levels. Although arbitrarily defined, the ranges fit the data very well, as illustrated in Figure 7. The ultrasonic waveform presented in Figure 6 does not show the audio portion since the wave velocity is so slow that it is off the range depicted in the Figure. Notice the amplitude decay profiles in Figure 7 for the ultrasonic level, the audio, and the mid-range level in examining all of the signals. Considering a reasonable noise level value, propagation distances up to 7000 feet were easily achieved.

### Air-coupled transducers

A number of non-contact sensor types were evaluated: EMATs, laser vibrometers, microphones, and so forth. Only air-coupled transducers had the receiving capability and frequency response to detect signals in the desired frequency range and at the required lift-off distances. Transducers were obtained from Second Wave Corporation in Boalsburg, PA. In fact, such transducers were shown to detect ultrasonic rail signals five feet vertically above a railhead.

The techniques used to acquire data are illustrated in Figure 8, along with a sample waveform.

To further understand the reception response of the air-coupled transducers, a set of experiments was conducted placing the

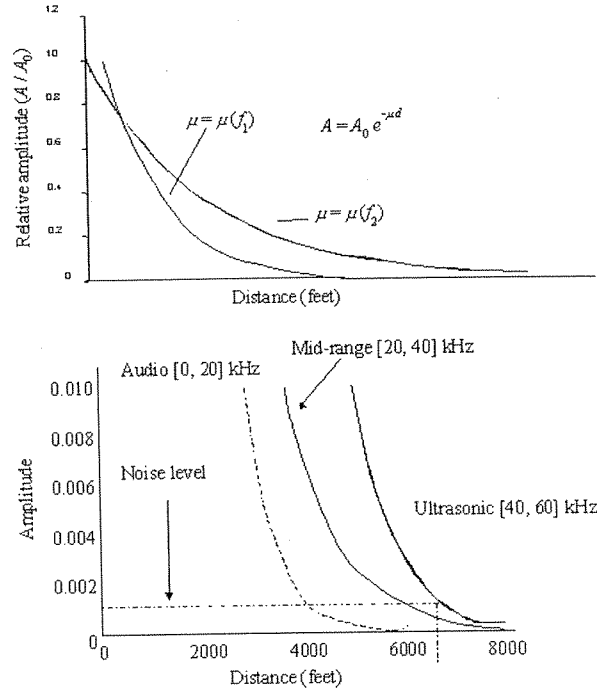

Figure 7. Model of frequency-dependent attenuation and comparison of attenuation characteristics for three frequency ranges. Modes at specific frequencies have specific attenuation characteristics

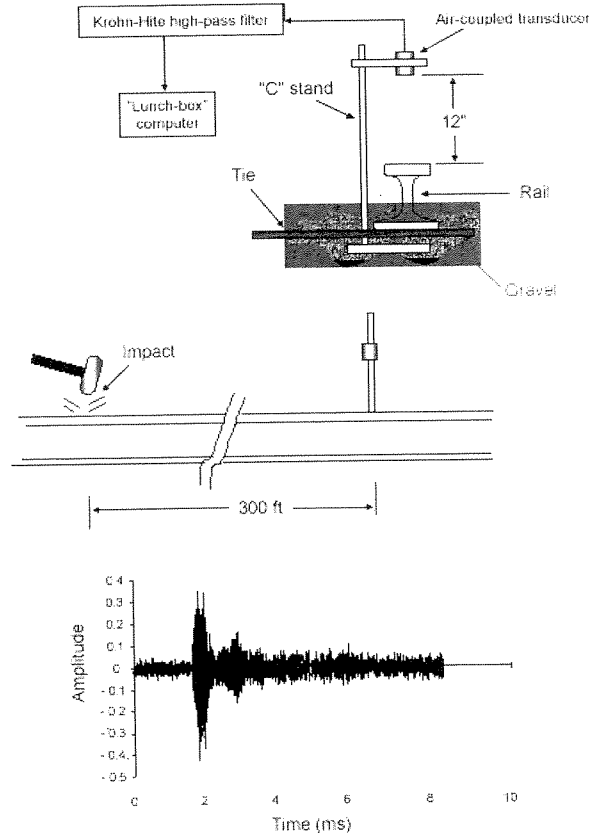

Figure 8. Air-coupled sensing and sample received waveform

transducer at selected distances and angles relative to the head top centre. See Figure 9.

Five angles and six distances,  $d$ , were used. The angles were  $0^\circ$  (looking at the side of the rail head),  $30^\circ$ ,  $45^\circ$ ,  $60^\circ$ , and  $90^\circ$  (looking down on the head). The distances ranged from two inches to twelve inches in two-inch increments.

Because of limitations to our mechanical configuration for angle measurements, only  $0^\circ$  and  $90^\circ$  measurements could be made for the two-inch distance,  $d$ .

Figure 10 and 11 show the results of these experiments.

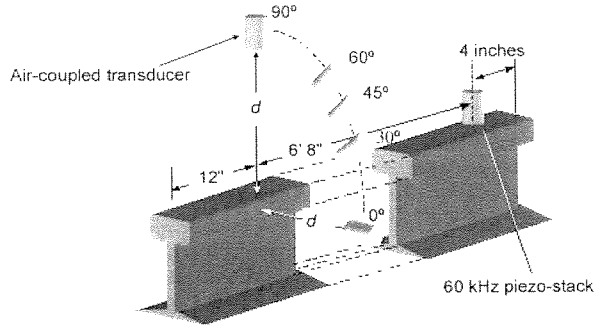

Figure 9. Configuration for receiving angle experiments

### Rail cut experiments

Several rail-cutting experiments were conducted to evaluate the possible relationships between signals acquired and depth of cut. Of primary concern was the possibility of seeking out a monotonic change in amplitude with cut depth. For certain modes and frequency values this should be possible, as indicated in literature<sup>[4]</sup>. An overview of the exercise is indicated in Figure 12. Results for a 60 kHz piezostack normal beam transducer loading in pulse echo are presented in Figure 13 with data acquired from both sides of the cut approximately 15 feet away. Reasonable results are obtained but better results might be obtained with a different mode and frequency. Through-transmission results are shown in Figure 14. Again, reasonable results are obtained.

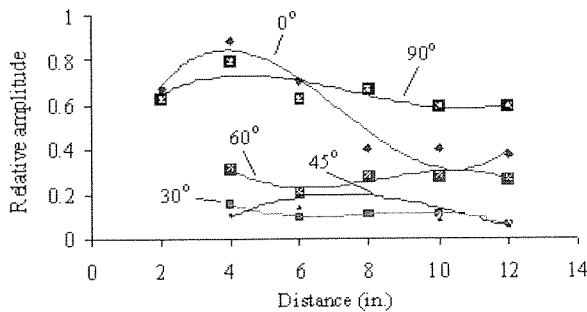

Figure 10. Variation of transducer response versus distance for all evaluated angles

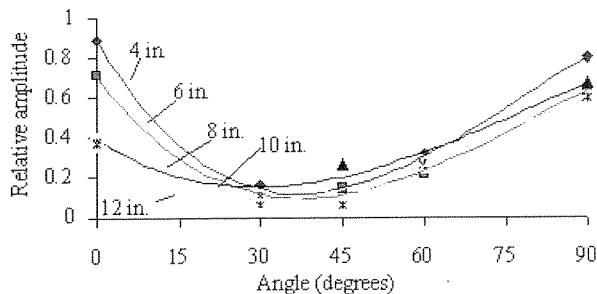

Figure 11. Variation of transducer response versus angle for the distances shown

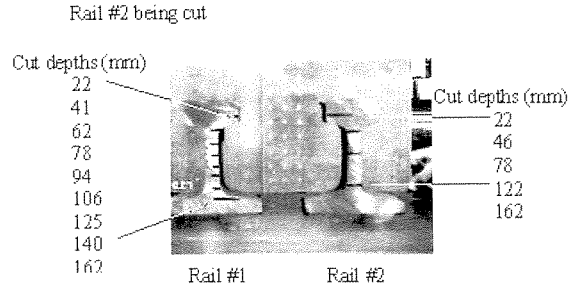
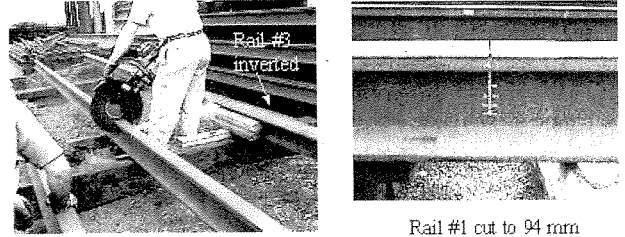

Figure 12. Overview of the manner in which the cutting was performed

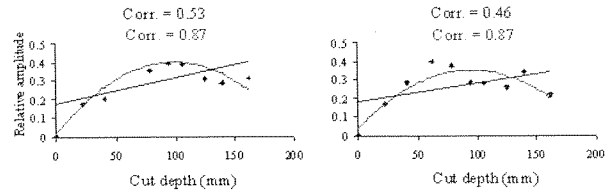

Figure 13. Scatter plot of pulse echo amplitude as a function of cut depth including trend lines from both sides of the cut

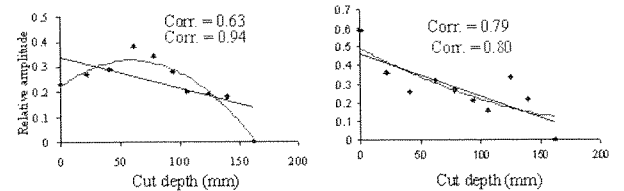

Figure 14. Scatter plot of through transmission amplitude as a function of cut depth including trend lines for the 60 kHz piezo stack sender and receiver from the sender at both sides of the cut

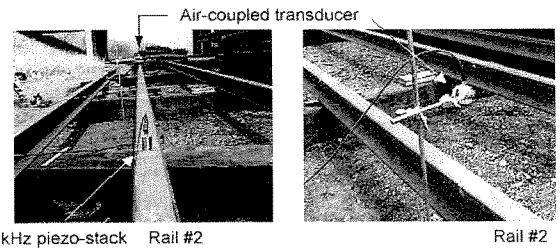

Figure 15. Photographs of air-coupled transducers as used during the second rail cutting experiment

Another set of experiments was conducted with an air transducer as a receiver, see Figure 15. Results, shown in Figure 16, are reasonable. Looking from the other side, similar results are obtained, see Figure 17.

Two sample RF waveforms for the air transducer receiver case are shown in Figure 18.

Another set of experiments was conducted with 60 kHz SH EMAT transducers. Excellent waveforms are obtained; see Figure 19 for the waveform at various distances. Attenuation profiles of the data are illustrated in Figure 20. Rail cut experiments were limited in this case, but results are depicted in Figure 21. The result was as expected.

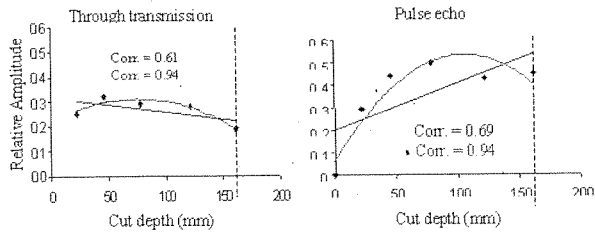

Figure 16. Graphical representation of the results from the 60 kHz piezo stack sender/air transducer receiver experiment with trend lines shown. Dashed lines indicate the total through rail depth

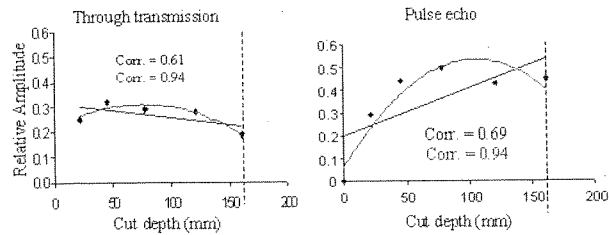

Figure 17. Graphical representation of the results from the 60 kHz stack sender/air transducer receiver experiment with trend lines shown from the opposite side of the cut

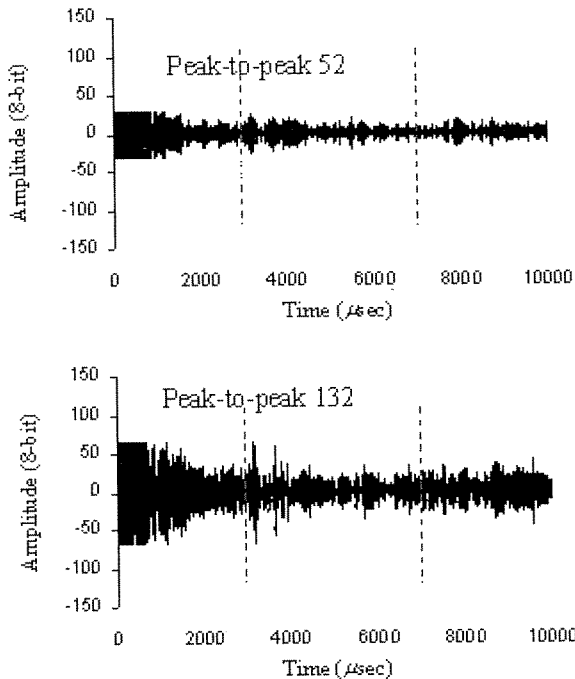

Figure 18. Sample pulse echo response for the 60 kHz piezo stack sender and air transducer receiver (echo amplitude recorded in gate shown)

## Conclusions

We believe that we have demonstrated that ultrasound guided wave propagation can be initiated in rail by transducers, impact devices, and trains. The frequency ranges that support guided wave propagation in rail have been identified. We have shown that air-coupled, EMATs and piezoelectric transducers can be used to monitor propagation in rail. The acquisition of the data to support these conjectures was facilitated by the use of the PC lunchbox computer system that we developed.

Several approaches for rail defect detection systems are possible:

- Detection of broken rail with permanently rail-mounted sensors with either piezoelectric or impact devices acting as sound sources.
- Detection of broken rail with signal processing schemes and permanently mounted sensors using trains as a sound source.
- Detection of defects in rail with guided waves generated and received by various sender and receiver elements mounted on a rail car.

Our experimental evidence has shown that Thermite welds exhibit a range of transmission/reflection characteristics and often absorb up to 1/2 of the impinging ultrasonic energy. This is a serious problem to be overcome. Shop welds, on the other hand, were consistent and exhibited good sound transmission properties, showing almost no loss or absorption of ultrasonic energy. Angle bar joints transmission/reflection characteristics also varied considerably, but most importantly, at the particular field site studied, they reflected a significant amount of ultrasonic energy. A so-called 'no-break', therefore, can often look something like a 'break'.

A low-frequency continuous wave (CW) power transducer was also used, more typical of the continuous energy input expected from a train. Standing waves were observed with features strongly dependent on probe position and the specific geometry of rail; weld

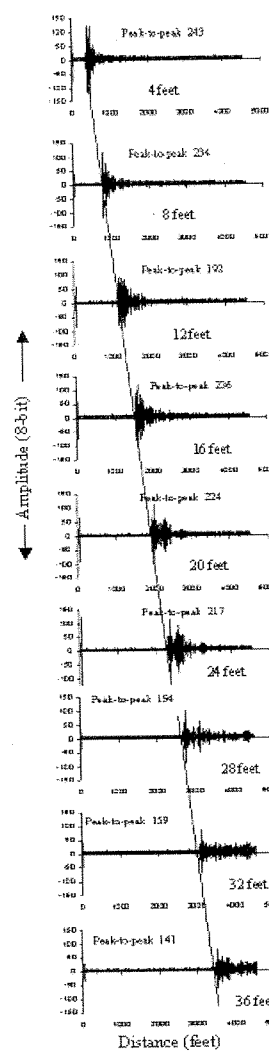

Figure 19. Normalised graphs of received through-transmission pulses at various distances for 60 kHz EMAT transducers

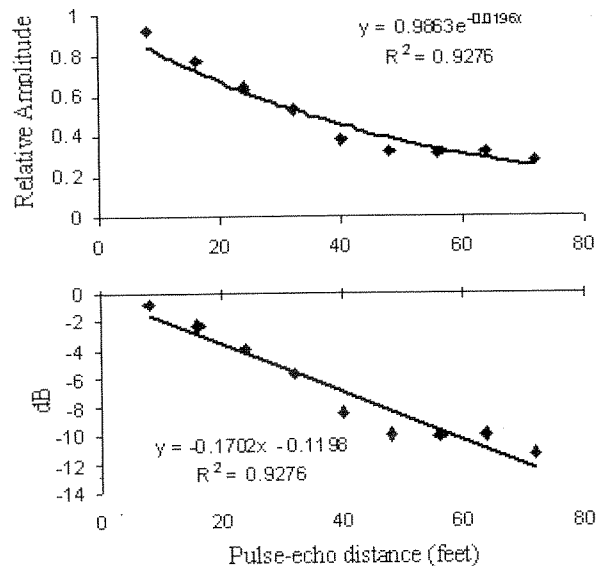

Figure 20. Graphical representations, with trend analysis, of EMAT pulse-echo results

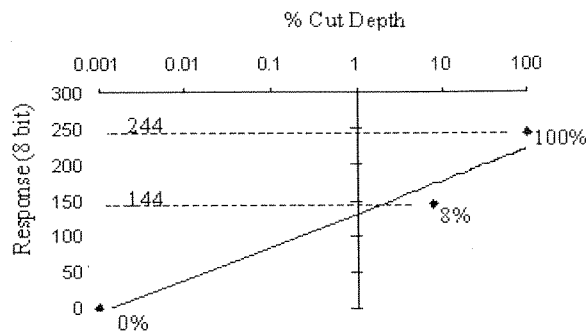

Figure 21. Pulse echo results 13' 2½" away from defect; logarithmic trend line also shown

type, angle bar joint, switch, location, etc. Probe position was critical. It is our feeling that a sensor mounted on a train could provide better discrimination results than a sensor at a fixed position on the rail unless using five or six fixed sensors to obtain optimum signals.

Lastly, much more work on quantification of defects in rail is needed, including that to determine defect classification and sizing.

### Acknowledgment

Thanks are given to the Federal Railway Administration, Bay Area Rapid Transit, TWI/Plant Integrity, Nittany and Bald Eagle Railroad for their support of this project.

### References

1. Rose, J L, 'Standing on the Shoulders of Giants - An Example of Guided Wave Inspection', Mehl Honor Lecture, Materials Evaluation, Vol 60, No 1, January 2002.
2. Rose, J L, 'Ultrasonics Waves in Solid Media', Cambridge University Press, 1999.
3. Rose, J L, Avioli, M J, 'Elastic Wave Analysis for Broken Rail Detection', TONE: Nondestructive Testing and Evaluation (NDT&E) for the Railroad Industry, ASNT, December 2001.
4. Rose, J L, Avioli, M J, 'Elastic Wave Analysis for Broken Rail Detection,' 15<sup>th</sup> World Conference on Nondestructive Testing, Rome, Italy, October 15-21, 2000.
5. Rose, J L, Zhao, X, 'Anomaly throughwall depth measurement potential with shear horizontal guided waves', Materials Evaluation, Vol 59, No 10, pp 1234-1238, Oct. 2001.

Step on it &  
get the speed  
of service you  
deserve!

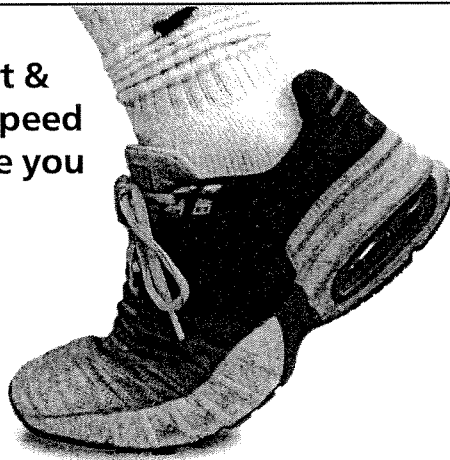

Either we get your equipment serviced within 7 working days\*, or we'll foot the charge for the work!

This new policy supports Hocking's continuing dedication to providing you with the best repair and calibration services on the market.

For more information on this offer, please contact us on the numbers below, or visit [www.hocking.com/service.htm](http://www.hocking.com/service.htm)

**HOCKING**

\*conditions apply

Hocking NDT Ltd • 129-135 Camp Road • St Albans • Herts • AL1 5HL • UK  
Tel: +44 1727 795544 • Fax: +44 1727 795444 • [service@hocking.com](mailto:service@hocking.com)

## Carbon Steel Tubes in Heat Exchangers

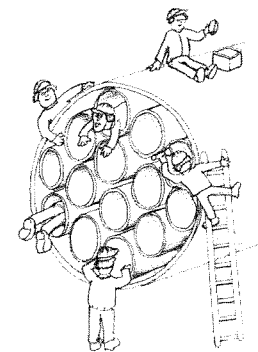

### DINSEARCH 1-00

Electromagnetic System  
for  
Rapid Inspection

Dinsley Devices Ltd., Ivy House  
Streatlam Park, Barnard Castle,  
County Durham DL12 8TZ  
Tel/Fax 01833 637 971